

Lektion 62: Slide (2)

In Lektion 57 haben wir die Spieltechnik Slide (auch Glissando genannt) kennengelernt. Wir rutschen dabei mit dem Finger der linken Hand den Hals auf- bzw. abwärts. Im Notenbild wird Slide durch einen kleinen Strich zwischen 2 Noten dargestellt. In L57 wurde auch ein Fingersatz für die Dur-Pentatonik präsentiert, der sich gut mit Slide spielen lässt. In dieser Lektion geht es nun um einen entsprechenden Fingersatz für die Moll-Pentatonik (zur Moll-Pentatonik siehe auch L49).

Hier sind die entsprechenden Fingersätze. Wie immer ist der Grundton mit G markiert. Bei dem ersten Fingersatz befindet sich der Grundton auf der E-Saite, beim 2. auf der A-Saite.

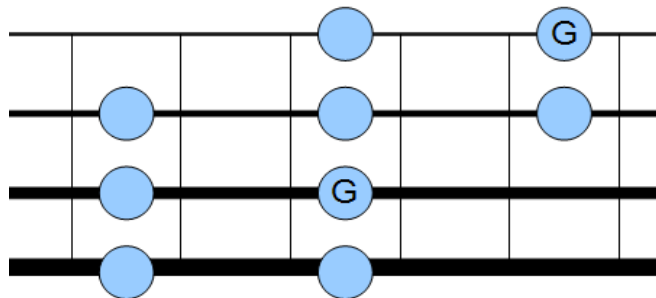
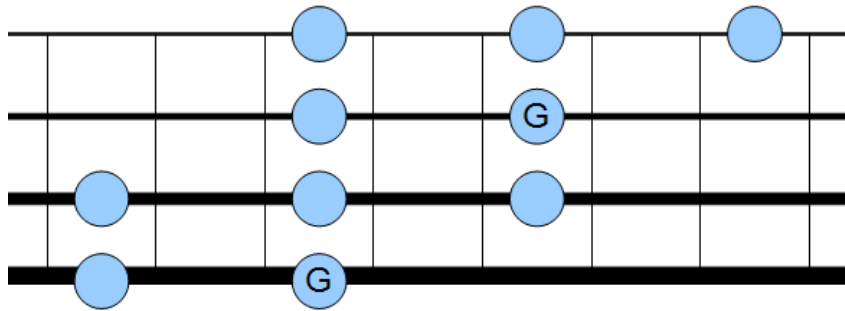

Übungen

1.) Spiele Übung 1 mit dem ersten oben präsentierten Fingersatz. Über den Noten ist die Lage, in der Du spielst, mit römischen Ziffern markiert.

a)

Exercise 1a: A single staff of music in bass clef with a key signature of one flat (B-flat) and a 4/4 time signature. The music consists of two measures of eighth-note patterns. The first measure contains the notes G2, F2, E2, D2, C2, B1, A1, G1. The second measure contains the notes F1, E1, D1, C1, B0, A0, G0, F0. Roman numerals are placed above the notes: V, III, V III, V, III, V III. A small '8' is written below the first note of the first measure.

b)

Exercise 1b: A single staff of music in bass clef with a key signature of one flat and a 4/4 time signature. The music consists of two measures of eighth-note patterns. The first measure contains the notes G2, F2, E2, D2, C2, B1, A1, G1. The second measure contains the notes F1, E1, D1, C1, B0, A0, G0, F0. Roman numerals are placed above the notes: V, VII V, VII V, VII V, VII V, VII. A small '8' is written below the first note of the first measure.

c)

Exercise 1c: A single staff of music in bass clef with a key signature of one flat and a 4/4 time signature. The music consists of two measures of eighth-note patterns. The first measure contains the notes G2, F2, E2, D2, C2, B1, A1, G1. The second measure contains the notes F1, E1, D1, C1, B0, A0, G0, F0. Roman numerals are placed above the notes: III, V, VII V, V, III. A small '8' is written below the first note of the first measure.

2.) Wie 1 aber benutze den anderen Fingersatz.

a)

Exercise 2a: A single staff of music in bass clef with a key signature of one flat and a 4/4 time signature. The music consists of two measures of eighth-note patterns. The first measure contains the notes G2, F2, E2, D2, C2, B1, A1, G1. The second measure contains the notes F1, E1, D1, C1, B0, A0, G0, F0. Roman numerals are placed above the notes: III, V III, V VII V, VII V, III. A small '8' is written below the first note of the first measure.

b)

Exercise 2b: A single staff of music in bass clef with a key signature of one flat and a 4/4 time signature. The music consists of two measures of eighth-note patterns. The first measure contains the notes G2, F2, E2, D2, C2, B1, A1, G1. The second measure contains the notes F1, E1, D1, C1, B0, A0, G0, F0. Roman numerals are placed above the notes: V, III, V, III, V. A small '8' is written below the first note of the first measure.

c)

Exercise 2c: A single staff of music in bass clef with a key signature of one flat and a 4/4 time signature. The music consists of two measures of eighth-note patterns. The first measure contains the notes G2, F2, E2, D2, C2, B1, A1, G1. The second measure contains the notes F1, E1, D1, C1, B0, A0, G0, F0. Roman numerals are placed above the notes: V, III, V, III, V. A small '8' is written below the first note of the first measure.